

INSTALLATION INSTRUCTION FRONT CAMBER/CASTER "QUICK CAM"

1. Perform pre-alignment checks in a normal manner.
2. Hook-up alignment equipment and record readings.
3. Support truck by the lower control arms.
4. Work on one control arm frame bracket at a time
5. Remove existing control arm cam guide and discard. (Fig. 1)
6. Install new "Quick Cam". (Fig. 2)
7. Use a 5/16 allen wrench to adjust alignment readings.
8. Torque cam guide nut to manufacture specification.
9. Set toe and road test vehicle.

(Fig. 1)

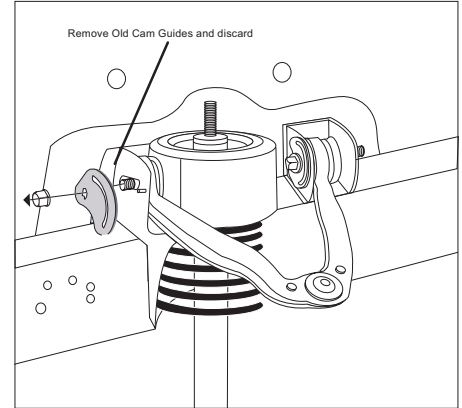

(Fig. 2)

